



LouverDrape® Zirlon® Wheeled System

Versatile top quality vertical headrail system for commercial office applications.



KEY FEATURES:

- Self-lubricating wheeled system glides smoothly
- Carriers stack in 30% less space
- Vanes rotate 360 degrees
- Easy to clean windows louvers move away from control end effortlessly
- Available in several vane styles
- Optional AutoWand™ feature
- One year warranty

PRODUCT OVERVIEW

Exclusive to LouverDrape®, the Zirlon® Wheeled System was designed for durability and superior performance even when used by people unfamiliar with vertical blinds—such as in hospitals, schools and hotels.

The Zirlon® system features carriers that are only 5/16" wide instead of the standard 7/16", which means that the blinds will stack in considerably less space when drawn. For design purposes, the smaller stacking advantage means that a smaller wall pocket is needed to contain the drawn blinds.

The Zirlon® Wheeled Headrail System is compatible with LouverDrape's entire line of vinyl, vinyl with fabric insert, perforated vinyl and fabric vanes.

The **AutoWand™** option replaces the usual cord and chain controls with a single plastic wand which opens and closes the vanes as well as glides them along the track to traverse the blinds. An especially desirable safety feature in schools and hospitals, AutoWand™ provides insurance against future service repairs.



Zirlon® Wheeled System

PRODUCT SPECIFICATIONS

For more detailed specifications please reference Zirlon® product Guide Specifications.

Part II – Products

A. Zirlon® Wheeled System Vertical Blind manufactured by Levolor

B. Lifetime Warranty

C. Materials:

- ⌘ **Headrail** shall be of anodized extruded aluminum alloy 1 5/16" wide x 7/16" high. Headrail finish shall be clear anodized aluminum.
- ⌘ **Carriers** shall be made of Delrin® and shall traverse on two Zirlon® wheels. Each carrier shall be nominally 5/16" wide for minimal stack.
- ⌘ **Rotation Control** shall consist of a #6 nickel-plated bead chain to synchronize and actuate 360 degree rotation.
- ⌘ **Traversing Control** shall allow blinds to traverse left to right, right to left or split. Blinds shall traverse by means of a non-stretch traverse cord traveling along smooth surfaces.
- ⌘ **Installation Brackets** shall be provided for overhead, wall or ceiling installations using the following:
 - a. Thumb clamps.
 - b. Angle brackets.
- ⌘ **Vanes** shall be (select one):
 - a. Extruded PVC nominally 3 1/2" wide. Perforated option available.
 - b. Fabric PVC nominally 3 1/2" wide.
- ⌘ **Options** shall include:
 - a. AutoWand™ which uses a wand control to both rotate and traverse vanes.
 - b. Recessed headrail.



AutoWand

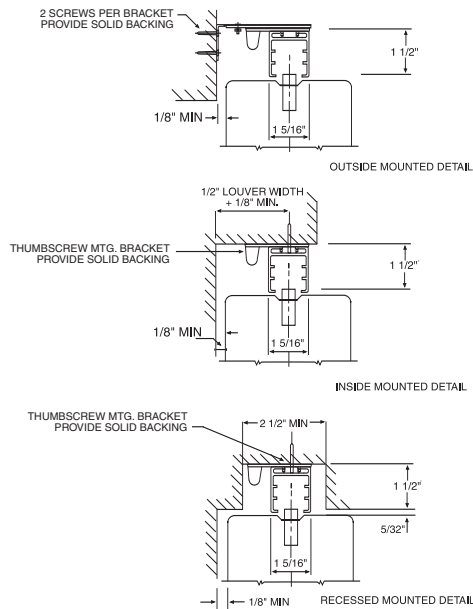

Note: Lift-out headrail shown in all diagrams.



Levolor Contract
4110 Premier Dr.
High Point, NC 27265

Contract Customer Service
1-800-826-8021
www.levolorcontract.com

© Copyright 2004 Levolor. All rights reserved. US and non-US patents and patents pending. Product specifications are subject to change without notice. Printed in the USA.

R0203034