



## Custom 1" Wood Blind

Model #WOOD1

The designer's choice for elegant, traditional window treatments.



### KEY FEATURES:

- **Finest premium kiln-dried hardwood construction**
- **Matching valance, bottomrail, wand, and tassel**
- **One year warranty**

### PRODUCT OVERVIEW

Levolor Custom 1" Wood Blinds create a soft casual look while adding natural warmth to any setting. Committed to both durability and aesthetics, the Levolor Custom 1" Wood Blind combines the highest quality components with visibly attractive features to provide an overall superior product.

Levolor Custom 1" Wood Blinds are made from the finest kiln-dried premium quality hardwood. Furniture quality wood finishes are available in two surface textures and a palette of more than 15 paints and stains ranging from contemporary light to rich, traditional dark tones. The standard finish is sanded smooth on all surfaces resulting in a quality blind free of chips, cracks and sawmarks.

Levolor wood blinds use a proven, high quality headrail system made of roll-formed corrosion-resistant Tomized steel. The metal headrail and precision quality components provide superior support for the additional weight demands imposed by wood blinds. The Tomized steel drums and cradles insure accurate alignment of moving parts, smooth and maintenance-free operation.

Valance returns have a precise mitered joint secured with an easy-to-assemble return clip. The premium hardwood slats, bottomrails, and styled valance are color coordinated with cords, ladders, wands and tassels to provide an elegant wood window covering.



# Custom 1" Wood Blind

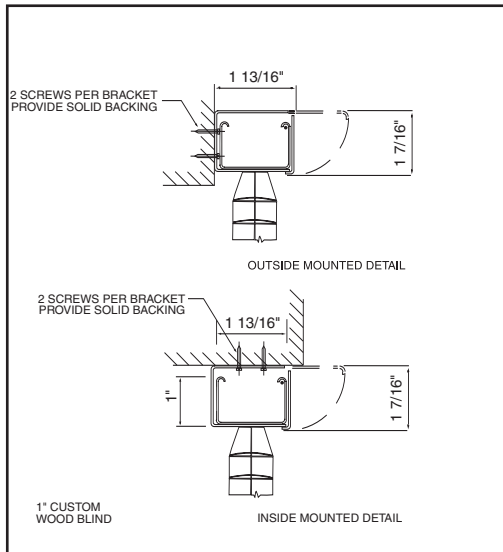
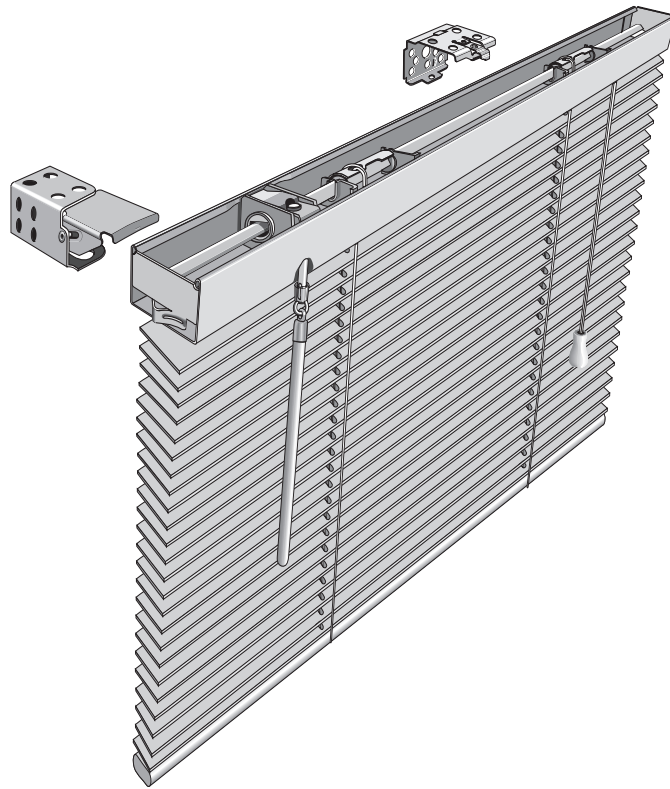

Custom 1" Wood mounting detail

## PRODUCT SPECIFICATIONS

For more detailed specifications please reference Custom 1" Wood Blind product Guide Specifications.

### Part II – Products

**A. Custom 1" Wood Blind manufactured by Levolor**

**B. One Year Warranty**

**C. Materials:**

- n **Headrail** shall be of .025" thick Tomized steel, "U" shaped, 1" high x 1-9/16" wide. All hardware shall be enclosed in the metal headrail.
- n **Tilt Wand** shall be of hardwood, with a .38" diameter.
- n **Cord Lock** shall be .042" thick Tomized steel and shall be crashproof.
- n **Drum and Cradle** shall be provided for each ladder.
  - a. Drums shall be of .031" Tomized steel.
  - b. Cradles shall be of .042" Tomized Steel.
- n **Installation Brackets** shall be of at least .048" thick Tomized steel with a rivet-hinged safety locking front cover to permit removal of headrail without lateral movement.
- n **Ladders** (slat supports): Distance between 1" slats shall not exceed 21.5mm (nominally 14.2 slats per vertical foot).
- n **Slats** shall be of premium quality hardwood finished with a wood stain or solid coating selected from Levolor Custom colors, sealed, and lacquered. Maximum slat length is 96". Standard 1" slats are nominally 1" wide x 1/8" high.
- n **Bottomrail** shall be nominally 1" wide x 5/8" high and finished to coordinate with slats.
- n **Options** shall include:
  - a. Top-Lok cord Lock
  - b. Radius corners

© Copyright 2004 Levolor. All rights reserved. US and non-US patents and patents pending. Product specifications are subject to change without notice. Printed in the USA.

Contract Customer Service  
1-800-826-8021  
[www.levolorcontract.com](http://www.levolorcontract.com)



Levolor Contract  
4110 Premier Drive  
High Point, NC 27265